

How to Mod the MV-1FZ for Stereo Sound (by Jeff Kurtz)

<http://www.neobitz.com/Pages/Mods/MV1FZ-S.aspx>

Modding your MV-1FZ for stereo sound is a pretty simple process, so it shouldn't take a lot of time to perform.

The first thing you need to do is locate where to tap the stereo signal on the 1FZ. The following image is from the bottom side of the 1FZ board. Look around the board and locate this area as this is where you will tap the signals. I have marked three places of importance which I will explain below.

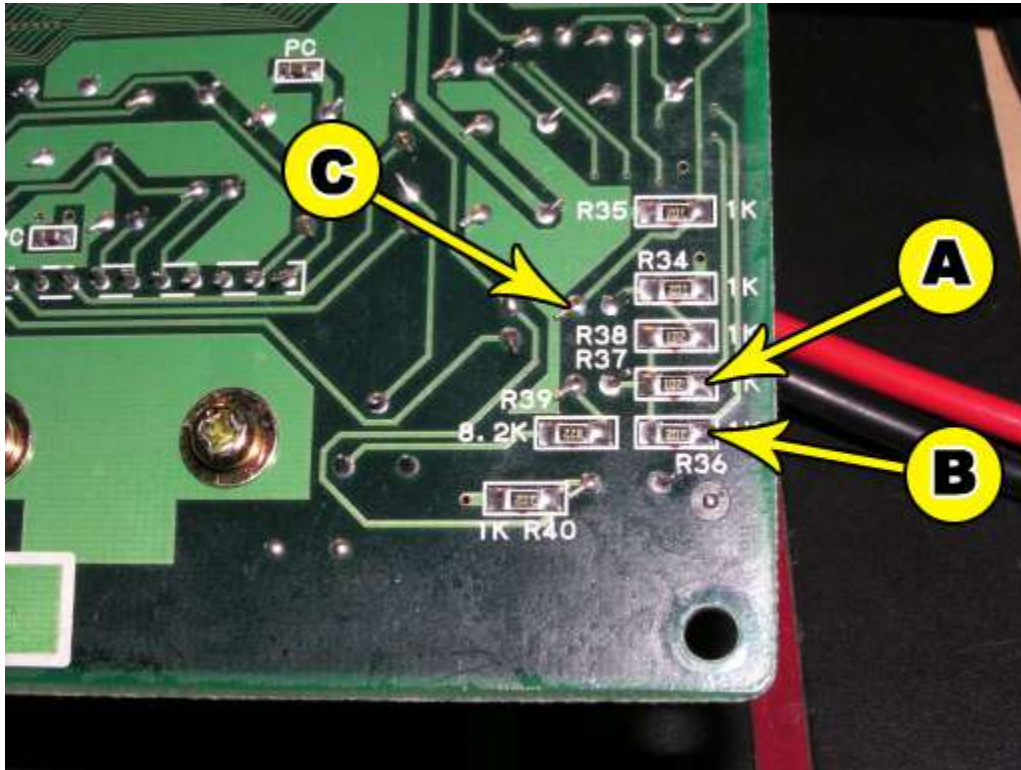

The stereo signal comes into the 1K resistors marked R37 (A) and R36 (B), along the right side of the image. The stereo signal is summed (into mono) with a third signal (C) that comes directly from the YM2610 audio. I haven't looked real close as to why it is a separate line but without it, you will be missing some sounds. This line is played over both the left and right channels. For your reference, (A) = Right Channel, (B) = Left Channel, and (C) = YM2610 Analog Channel.

To get stereo out of the 1FZ, the first thing that you will need to do is break the audio merge. You can do this by removing R36 and R37. By doing this though, you have lost the YM2610 analog channel that gets mixed into the mono signal. What you will need to do is wire up a small circuit to add the YM2610 analog channel into each stereo channel.

Now that you have the two resistors removed (R36 and R37), you will need to solder three pieces of wires to the pickup points indicated in the first image, as shown in the next image. I would recommend wire about 6 inches long to give you enough working area.

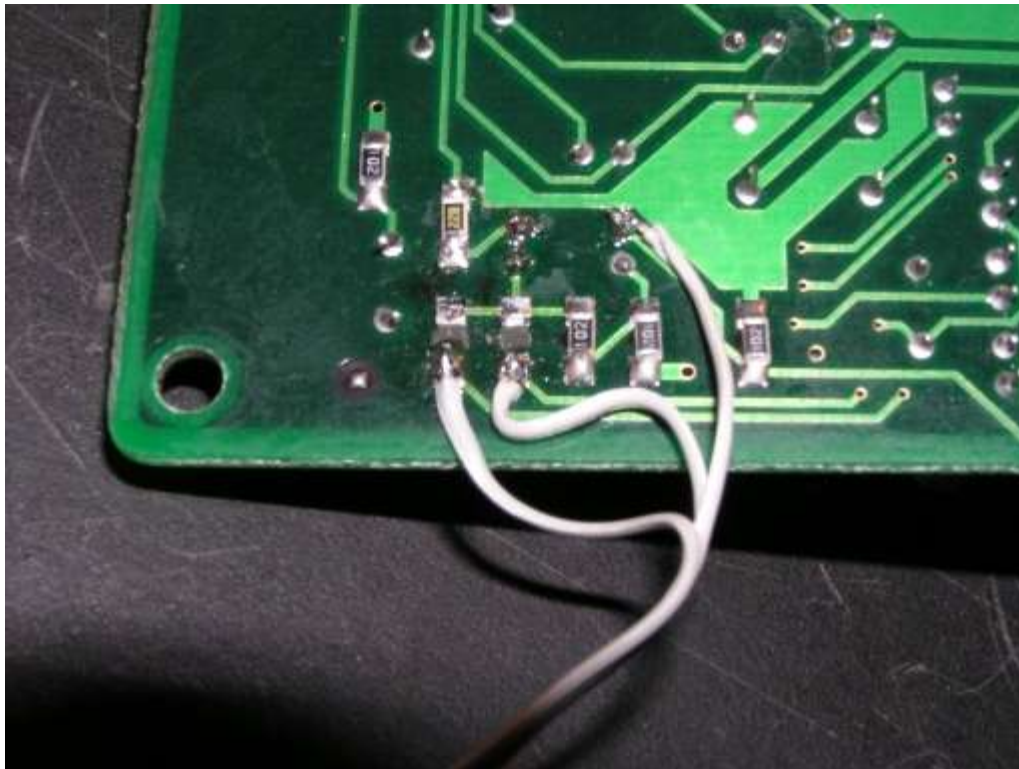

Now that you have the wires attached to the 1FZ board, you will need to build a small circuit that will mix the YM2610 Analog Channel (C) with the Right Channel (A) and Left Channel (B). The circuit is very simple and only requires four capacitors (4.7u) and four resistors (6.8k). The schematic and board are shown in the following image:

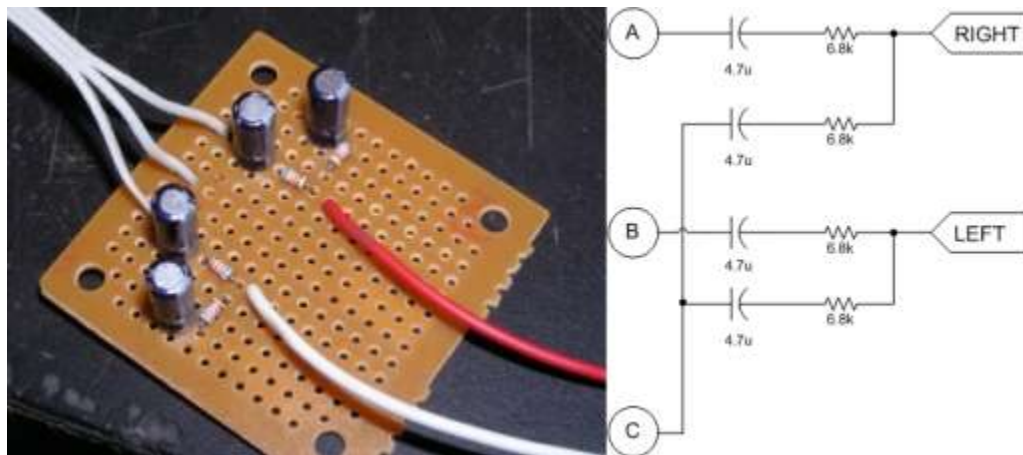

In the above photo, the Right Channel (A) is the top wiring coming in from the left. The middle wire is the YM2610 Analog Channel (C), and the bottom wire is the Left Channel (B).

In my testing, I just wired the Left and Right leads up to the RCA jacks on a consolized 1FZ and used the MVS Test Menu to verify that stereo was working. I didn't spend a great deal of time on this so if your audio is backwards, I may have mislabeled the LEFT and RIGHT channels :) I didn't wire the Left and Right channels to the MVS JAMMA edge to see if it was ample sound for a cabinet as my only goal for this was on a consolized system. In any case, it's a pretty simple mod and could be expanded on to fit your needs.

Notes by mmmonkey

I wanted a small board for this that that wasn't too tall, so bent the capacitors over. Here's a few photo's of it as I built it...

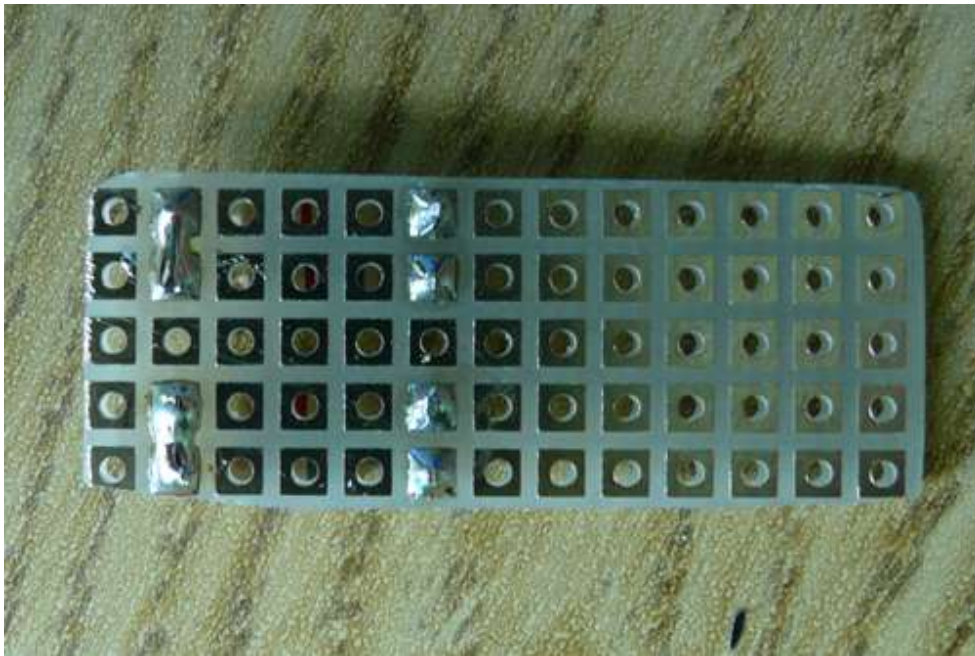
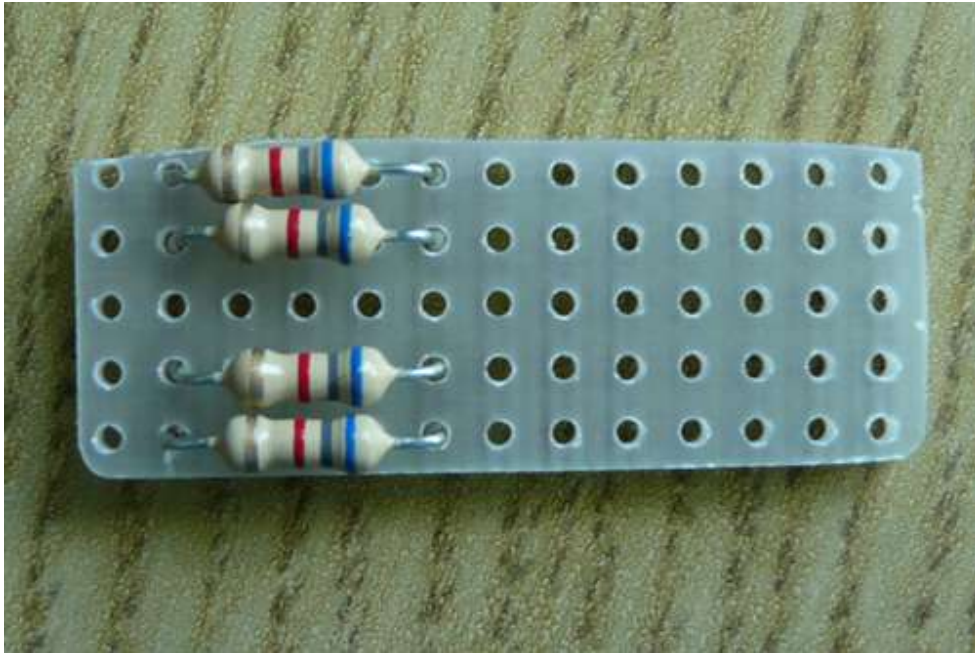

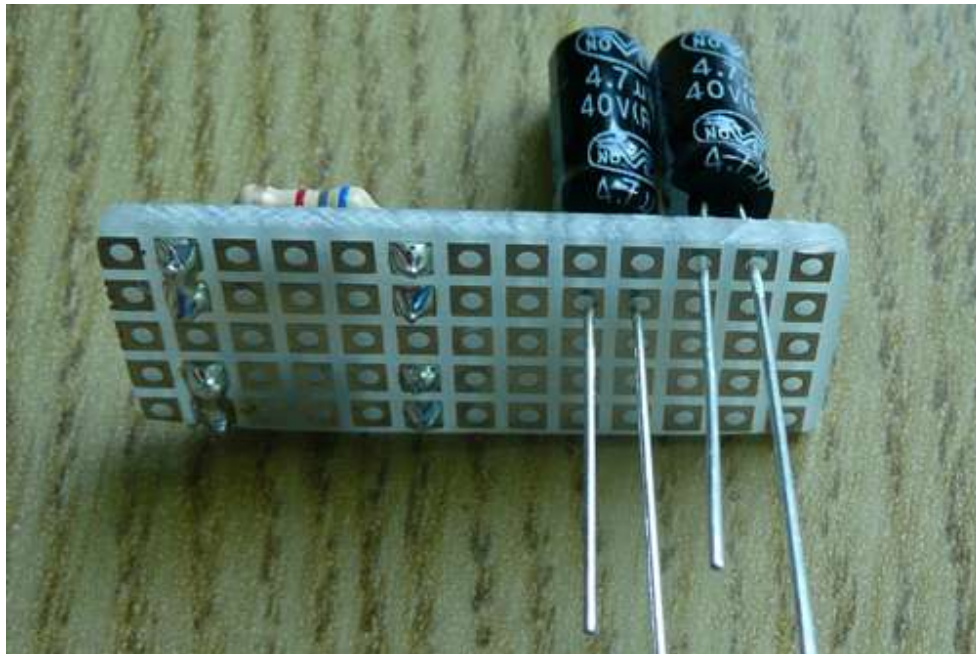

White stripe on Caps face the resistors

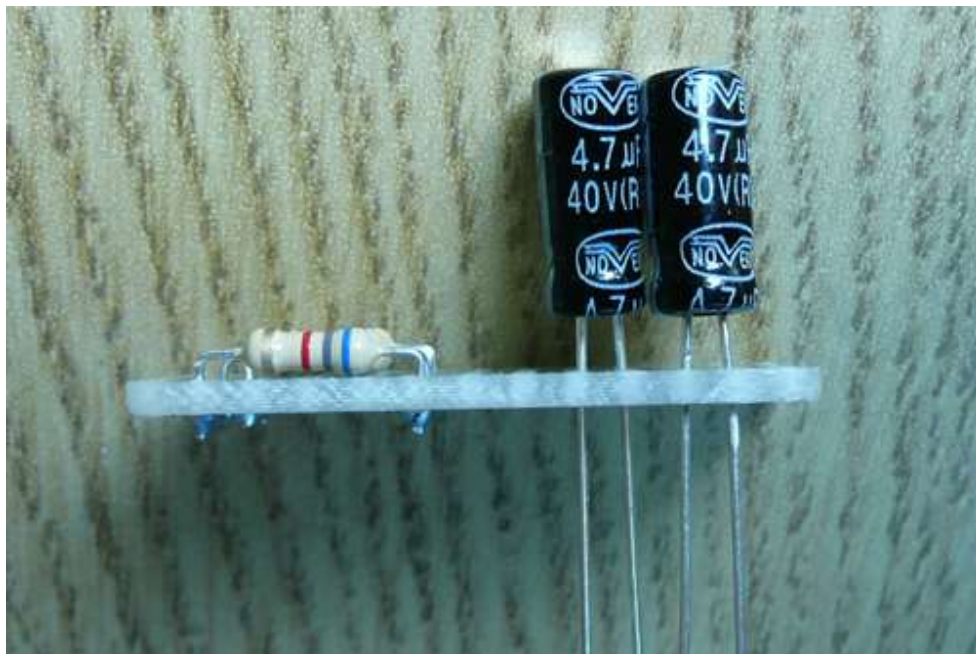

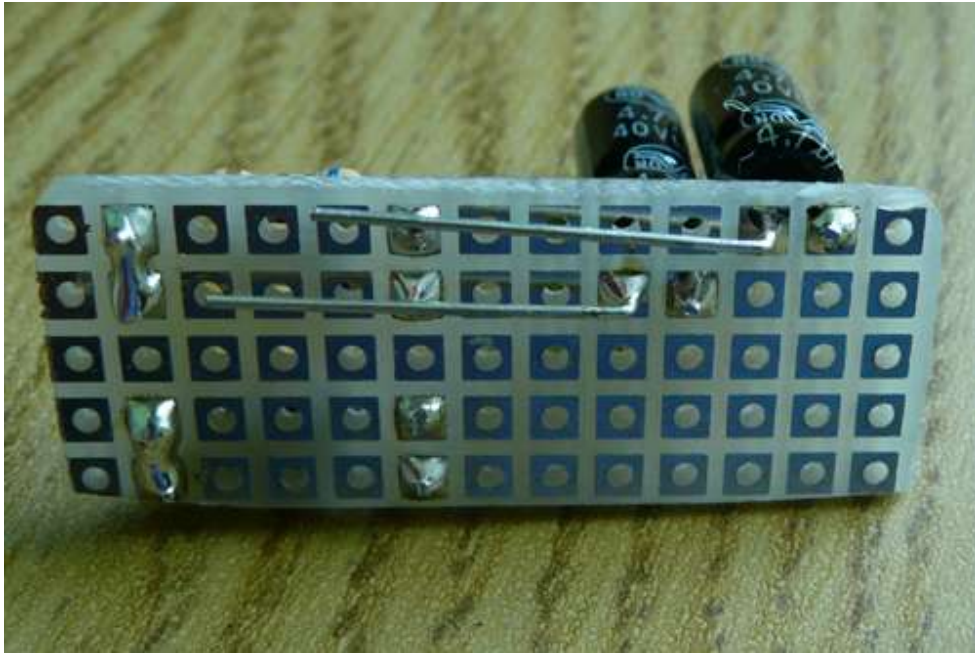

Negative legs bent to reach resistors, ready to be soldered in place and trimmed off.

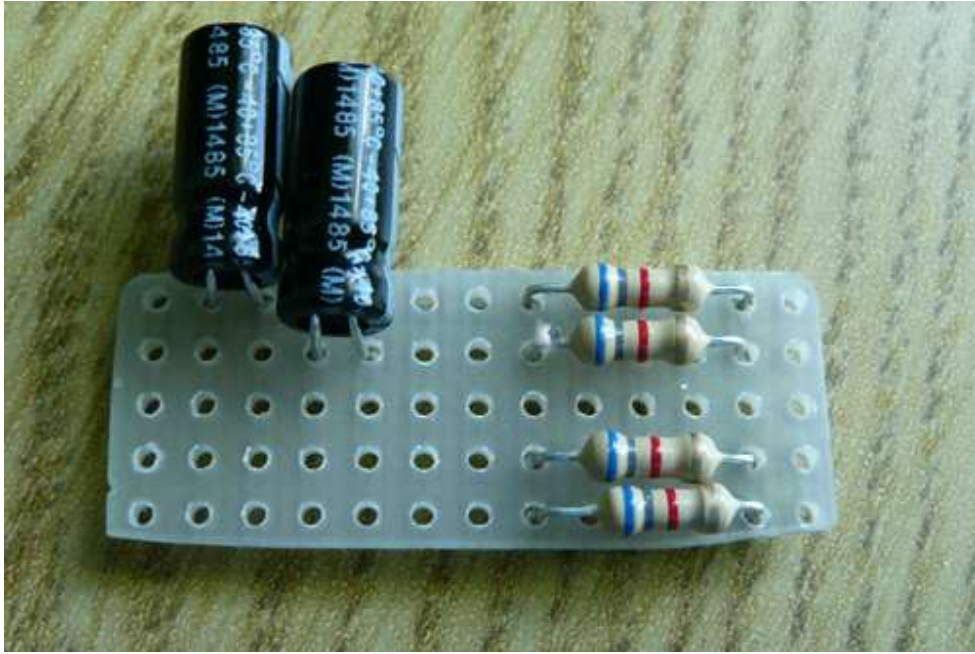

Capacitors bent over to reduce height.

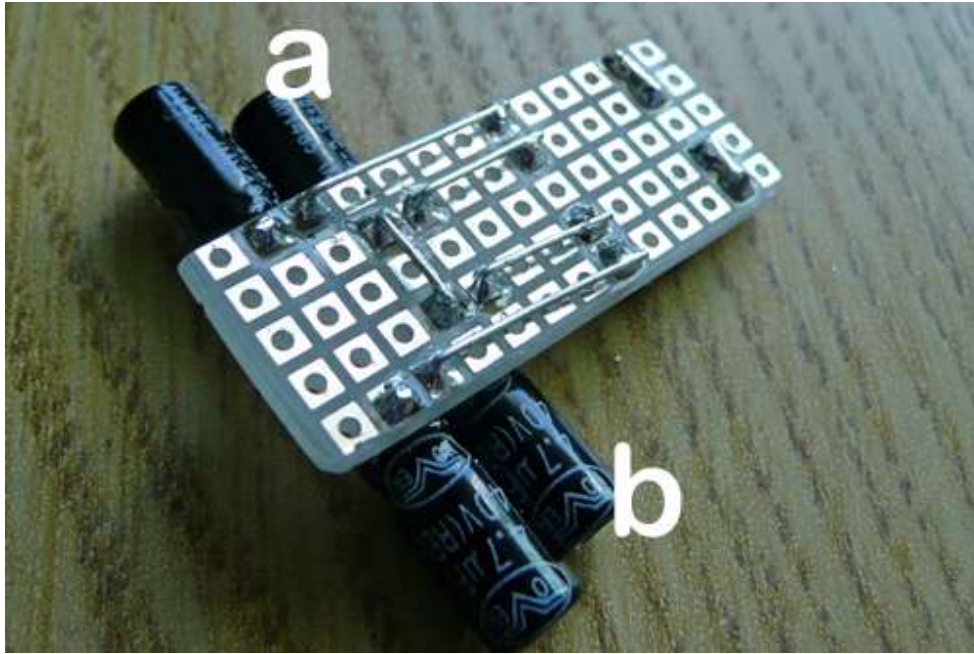

Last two capacitors soldered into place, note the link on the positive legs of capacitors A and B, this is the input for the centre channel.

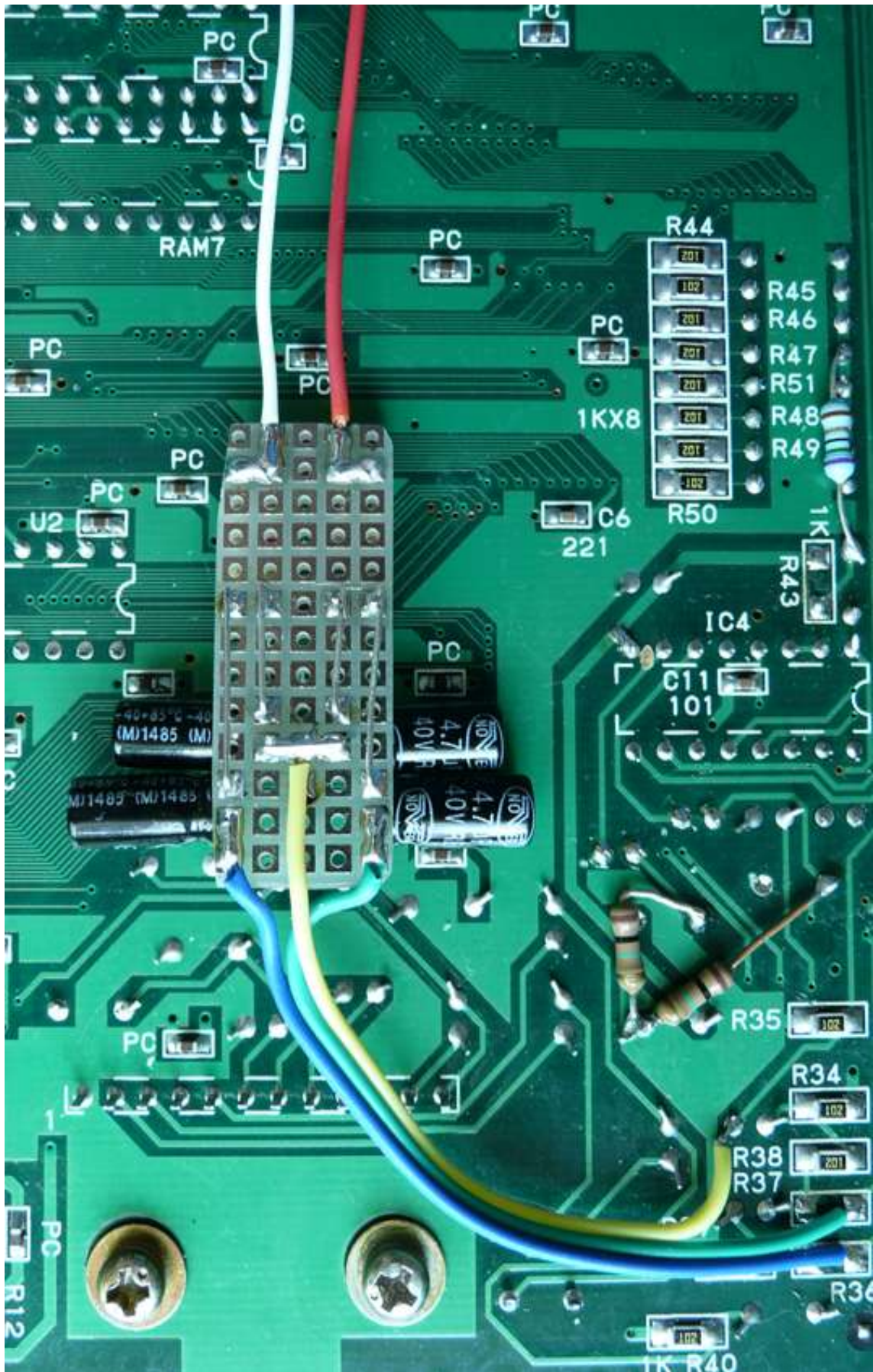

Green wire - Right Channel, Blue wire – Left Channel, Yellow wire – Centre Channel.
Red wire – Right Output, White wire – Left Output :-)